

# INDIVIDUAL COMFORT MODULES

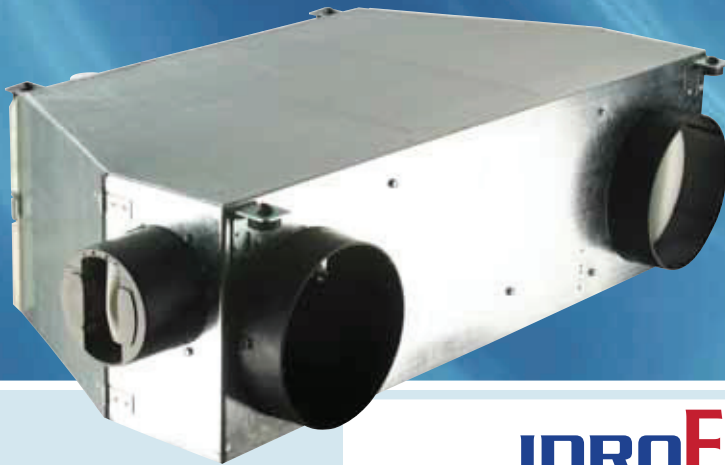

## Air treatment 42BJ



### Options/accessories

- Factory-installed two- or four-way valves
- High-efficiency filter
- Condensate pump

### Standard controls

NTC communicating controller



- Network communication
- Aquasmart Evolution system compatible
- IAQ and DCV management
- Motorised blinds and lighting control



Aquasmart New System Manager

### Features

- Three sizes with two-pipe, two-pipe plus electric heater or 4-pipe coils, with an air flow range from 16 to 250 l/s, a cooling capacity range from 0.5 to 6 kW and a heating capacity range from 0.5 to 12.5 kW.
- Compact, U-shaped ducted chilled-water fan coil systems, designed for installation above false ceilings in corridors.
- Reliable and economical cooling and heating for light commercial and office applications.
- Includes a centrifugal fan with a low-energy consumption (LEC) motor. This direct-drive motor is electronically commutated (EC motor). It is piloted by a 0-10 V signal that permits operation with a wide range of rotational speeds, varying from the base setting and is precise, simple and quiet. It also includes an air filter, a fresh air inlet with adjustable air quantity, a chilled-water cooling coil and a hot-water heating coil and/or an electric resistance heater.
- U-shape model with inlet and outlet on the same side.
- Compatible with the 35BD air diffuser range.
- Low height of 270 mm (sizes 1.9 and 2.9).
- Extra low sound level in ducted air distribution system.
- High-pressure centrifugal fans, compatible with air distribution systems up to 300 Pa.
- High-efficiency F5 or F6 filter.
- Safe factory-installed electric heater for single or two-stage hot water heating.
- Low hydraulic pressure drop with a valve mounted, compatible with all chiller pump kits.
- Quick installation with factory-installed options (controls, valves).
- Available with demand control ventilation (DCV) and CO<sub>2</sub> sensor.
- Improved market competitiveness.

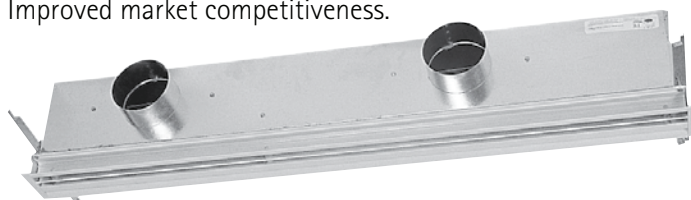

35BD linear diffuser (supply and return air)

## Physical and electrical data

42BJ ICM LEC		1.9			2.9			4.9		
Fan speed*		L	M	H	L	M	H	L	M	H
Air flow	l/s	16	116	190	25	163	224	40	220	239
	m <sup>3</sup> /h	58	418	684	90	587	806	144	792	860
Available static pressure	Pa	1	50	135	1	50	95	2	50	59
<b>Cooling mode**</b>										
Total cooling capacity	kW	0.46	2.6	3.65	0.68	4.06	5.3	1.3	5.14	5.43
Sensible cooling capacity	kW	0.33	2	2.93	0.47	3	3.99	0.89	3.8	4.05
Water flow rate	l/s	0.02	0.12	0.17	0.03	0.19	0.25	0.06	0.25	0.26
	l/h	80	448	628	118	699	912	224	884	935
Water pressure drop	kPa	2	27	47	2	39	61	5	61	68
Water content	l	0.9	0.9	0.9	1.2	1.2	1.2	1.5	1.5	1.5
<b>Two-pipe heating mode***</b>										
Heating capacity	kW	0.51	2.95	4.14	0.76	4.82	6.34	1.43	6.4	6.8
<b>Eurovent energy class FCEER/FCCOP</b>										
		C/C			B/B			B/B		
<b>Four-pipe heating mode****</b>										
Heating capacity	kW	0.69	3.1	4.04	1.09	4.37	5.22	1.94	6.4	6.71
Water flow rate	l/s	0.02	0.07	0.10	0.03	0.10	0.12	0.05	0.15	0.16
	l/h	60	267	348	94	376	449	168	550	577
Water pressure drop	kPa	1	15	23	4	32	41	8	67	73
Water content	l	0.2	0.2	0.2	0.29	0.29	0.29	0.45	0.45	0.45
<b>Eurovent energy class FCEER/FCCOP</b>										
		C/C			B/B			B/A		
<b>Electric heater</b>										
	V-ph-Hz	230-1-50								
Maximum capacity	kW	0.5	1.9	2.23	0.75	2.12	2.25	1	2.25	2.25
Maximum current drawn	A	11	11	11	11	11	11	11	11	11
<b>Sound levels</b>										
Sound power level (return + radiated)	dB(A)	29	50	59	34	52	59	33	60	62
Sound power level (supply)	dB(A)	26	57	66	20	63	69	31	69	72
Global sound power level	dB(A)	31	58	67	34	63	69	35	70	72
Sound pressure level†	dB(A)	10	37	46	13	42	48	14	49	51
NR value†	-	32	41	41	-	37	43	-	44	46
<b>Electrical data, motor</b>										
		230 V-1 ph-50 Hz, EC motor with low energy consumption								
Power input	W	4	49	160	4	68	174	5	46	186
<b>Air filter F5 or F6</b>										
	mm	240 x 400			240 x 550			315 x 550		
<b>Physical data</b>										
Connection diameter, chilled and hot-water coil	in	1/2 gas			1/2 gas			1/2 gas		
Spigot connection diameter	mm	200			200			250		
Length x depth x height	mm	900 x 665 x 270			1100 x 815 x 270			1100 x 815 x 345		
Unit weight (standard)	kg	31			40			50		

\* Fan speed: L = Low, M = Medium, H = High

\*\* Eurovent conditions: Entering air temperature 27°C/47% rh, entering water temperature 7°C, water temperature difference 5 K.

\*\*\* Eurovent conditions: Entering air temperature 20°C - entering water temperature 50°C, with same water flow rate as in cooling mode.

\*\*\*\* Eurovent conditions: Entering air temperature 20°C - entering water temperature 70°C, water temperature difference 10 K.

† Based on a hypothetical sound attenuation for the room and the system of -21 dB(A).

## Air distribution with Optimix linear diffusers

Cooling air flow

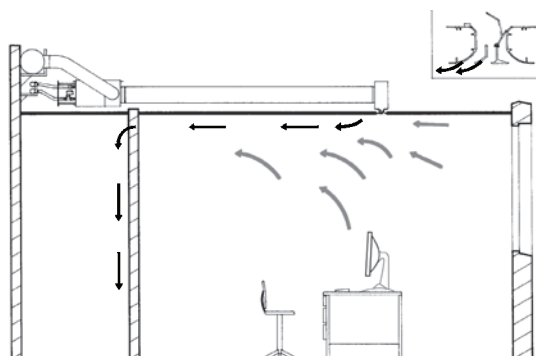

Heating air flow

